

## Space-Time LDPC with Layered Structure for MIMO Systems

Jianxuan Du, Ye (Geoffrey) Li, Daqing Gu, Andreas F. Molisch and Jinyun Zhang

TR2004-119 December 2004

### Abstract

In this paper, we incorporate the layered structure with low-density parity-check codes (LDPC) to develop a quasi-block diagonal LDPC space-time structure. The lower triangular structure of the parity check matrix introduces correlation between layers. In addition, each layer, as a part of the whole codeword, can be decoded while taking information from other undetected layers to improve the decoding performance. Belief propagation of the current layer is stopped as soon as those parity checks involving only the current layer and detected layers are satisfied. Simulation shows that the proposed system outperforms the conventional V-BLAST by 0.5 dB at WER=1%.

*Wireless Personal Multimedia Communications (WPMC)*

This work may not be copied or reproduced in whole or in part for any commercial purpose. Permission to copy in whole or in part without payment of fee is granted for nonprofit educational and research purposes provided that all such whole or partial copies include the following: a notice that such copying is by permission of Mitsubishi Electric Research Laboratories, Inc.; an acknowledgment of the authors and individual contributions to the work; and all applicable portions of the copyright notice. Copying, reproduction, or republishing for any other purpose shall require a license with payment of fee to Mitsubishi Electric Research Laboratories, Inc. All rights reserved.



# Space-Time LDPC with Layered Structure for MIMO Systems

Jianxuan Du, Ye (Geoffrey) Li  
School of Electrical and Computer Engineering  
Georgia Institute of Technology  
Atlanta, Georgia 30332-0250  
Email: {jxdu, liye}@ece.gatech.edu

Daqing Gu, Andreas F. Molisch, and Jinyun Zhang  
MERL Mitsubishi Electric Research Laboratories  
201 Broadway  
Cambridge, MA 02139  
Email: {dgu, molisch, jzhang}@merl.com

**Abstract**—In this paper, we incorporate the layered structure with *low-density parity-check codes* (LDPC) to develop a quasi-block diagonal LDPC space-time structure. The lower triangular structure of the parity check matrix introduces correlation between layers. In addition, each layer, as a part of the whole codeword, can be decoded while taking information from other undetected layers to improve the decoding performance. Belief propagation of the current layer is stopped as soon as those parity checks involving only the current layer and detected layers are satisfied. Simulation shows that the proposed system outperforms the conventional V-BLAST by 0.5 dB at WER=1%.

## I. INTRODUCTION

*Multiple-input multiple-output* (MIMO) wireless systems, i.e., systems with multiple antenna elements at the transmitter and receiver, have drawn enormous interest, due to the fact that their information-theoretic capacity increases linearly with the number of antenna elements [1] [2].

An important factor determining the MIMO system performance is the error correction code used to encode the data. For SISO systems, near-capacity achieving codes have gained prominence in recent years. LDPC codes, originally developed by Gallager [3] and revived in recent years [4] [5], are a type of capacity-approaching codes that is especially well suited for implementation in integrated circuits due to their inherent parallelizability. LDPC for MIMO fading channels has been studied in [6] [7].

The challenge with iterative decoding in MIMO systems is the extraction of a posteriori probabilities of bits from the observed signal vector, which is the superposition of all transmitted signals. The derivation of the a posteriori probability requires an exhaustive search of all possible signal combinations. The decoding complexity increases exponentially with the number of transmit antennas and is too complex to be implemented in real time. List (Sphere) decoding can be used to dramatically reduce the complexity. Still, a large list size is required to achieve good performance for systems with high-order modulation. Linear processing based space-time structure, such as V-BLAST [8] has been proposed, where the input data stream is demultiplexed with each substream independently coded using 1-dimensional coding, and simultaneously sent via different transmit antennas. The decoding can be carried out by linear nulling and decision-feedback interference-cancellation.

The problem with layered systems is the presence of error-propagation, and the layers to be first detected, which

usually have low *signal-to-noise ratio* (SNR) due to loss of signal power by linear nulling, are more likely to be incorrectly decoded. Therefore, optimum detection order can make a big difference for flat fading channels. However, when implemented in frequency-domain, the advantage of detection order is less obvious for frequency-selective channels since the signals transmitted from the same antenna will experience different fadings across the frequency.

In this paper, we propose a space-time structure based on LDPC, which, similar to the layered space-time structure proposed in [8], can be detected with linear processing for efficient decoding. The lower-block triangular structure of the parity check matrix for the proposed LDPC code introduces correlation between consecutive layers so that the layers can be decoded successfully with the help of information from later layers.

The rest of the paper is organized as follows. MIMO system model is briefly introduced in Section II. The concept of *quasi-block diagonal LDPC* (QBD-LDPC) is introduced in Section III. In Section IV, the encoding and decoding algorithms are described. Simulation result is given in Section V to evaluate the performance of the proposed system and the paper is concluded in Section VI.

## II. MIMO SYSTEM MODEL

In a flat-fading MIMO system with  $N_t$  transmit and  $N_r$  receive antennas, the relationship between transmitted and received signals can be expressed as

$$\mathbf{r} = \mathbf{G}\mathbf{x} + \mathbf{n},$$

where  $\mathbf{r}$  is a  $N_r \times 1$  received signal vector,  $\mathbf{x}$  is a  $N_t \times 1$  transmitted signal vector, and  $\mathbf{G}$  is a  $N_r \times N_t$  channel response matrix. The  $N_r \times 1$  noise vector  $\mathbf{n}$  has entries being independent and identically distributed (i.i.d.) zero-mean circular complex Gaussian random variables with variance  $N_0/2$  per dimension.

For frequency-selective channels, *orthogonal frequency division multiplexing* (OFDM) can be used to convert the channel into a number of parallel flat-fading channels with the help of cyclic prefix and *fast inverse Fourier transform* (IFFT) at the transmitter. The channel response matrix, in this case, is frequency-dependent.

### III. QUASI-BLOCK DIAGONAL LDPC SPACE-TIME CODES

In this section, we devise an LDPC space-time code structure where each layer comprises a subblock and consecutive blocks are correlated by the introduction of *connection matrices* in the parity check matrix. The main novelty is that instead of demultiplexing the input data into separate streams and encoding each one independently, we are able to extract information from later layers to help improve the detection performance of the current layer, which is critical in preventing the error propagation in decision-feedback interference cancellation detectors.

The parity check matrix structure of binary QBD-LDPC for a MIMO system with 2 transmit and 2 receive antennas is illustrated in Figure 1. The entire matrix is denoted as  $\mathbf{H}$  and any valid binary codeword  $\mathbf{b}$  satisfies

$$\mathbf{H}\mathbf{b} = \mathbf{0}.$$

Each layer has the same length of codeword but the code rates may be different for different layers, which implies the numbers of the information bits may be different. In addition to the blocks along the main diagonal, which would be the parity check matrices for independent layers if all  $\mathbf{C}_i = \mathbf{0}$ , Sparse connection matrices,  $\mathbf{C}_i$ , link two consecutive layers  $i$  and  $i + 1$  as a channel for exchange of information. The layers are decoded from layer 1 to layer 2 and at detection stage  $i$ , the next layer  $i + 1$  will also contribute to the decoding of layer  $i$ .

As observed in [9], those bits (variable nodes) with higher degrees tend to converge faster, which motivates the design of irregular LDPC since the quickly converged bits will make it easier to decode the rest. Similarly, the introduction of connection matrices can be regarded as adding degrees to bits in the layer  $i$  so that those bits are better protected. In other words, when decoding layer  $i$ ,  $\mathbf{H}_i$ ,  $\mathbf{H}_{i+1}$ , and  $\mathbf{C}_i$  form a smaller subcode where only the bits related to  $\mathbf{H}_i$  with higher degrees are to be decoded at the current stage. The decoding of layer  $i + 1$  will be carried out later, with better channel quality after cancelling the interference from layer  $i$ , and with more protection, since layer  $i + 2$  will contribute to the decoding.

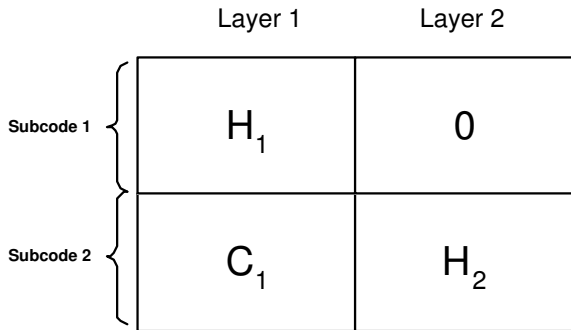

Fig. 1. Parity-check matrix structure for QBD-LDPC space-time codes

The system diagram of a QBD-LDPC based MIMO OFDM system is shown in Figure 2. Note that the output corresponding to each layer is permuted so that different parts of a layer are sent via different transmit antennas. The permutation is to guarantee all layers, on the average, have similar channel condition.

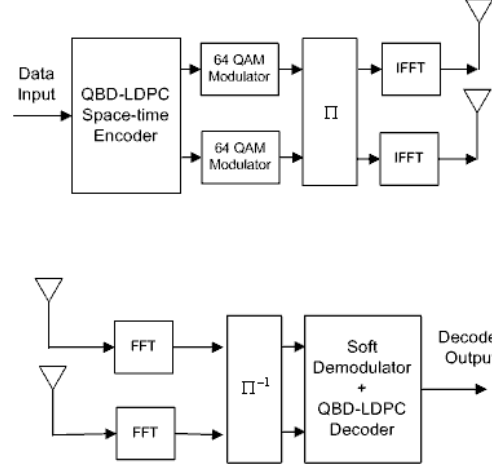

Fig. 2. System diagram of quasi-block diagonal LDPC space-time codes.

### IV. ENCODING AND DECODING OF QBD-LDPC SPACE-TIME CODES

In this section we are going to introduce encoding and decoding of the proposed space-time structure.

#### A. Encoding

Let  $n$  be the length of the codeword for every layer. Assume the number of parity check bits for layer  $i$  is  $r_i$ , and the  $(n - r_i) \times 1$  vector of input information bits is denoted as  $\mathbf{u}_i$ . The encoding of layer 1 is straightforward. By Gaussian elimination, we have

$$\mathbf{W}_1 \mathbf{H}_1 = (\mathbf{P}_1 \mathbf{I}_{r_1}),$$

where  $\mathbf{W}_1$  is a  $r_1 \times r_1$  full rank matrix carrying out Gaussian elimination on  $\mathbf{H}_1$ ,  $\mathbf{P}_1$  is a  $r_1 \times (n - r_1)$  matrix and  $\mathbf{I}_{r_1}$  is an  $r_1 \times r_1$  identity matrix. Then the codeword for layer 1 is formed by  $\mathbf{b}_1 = (\mathbf{u}_1^T (\mathbf{P}_1 \mathbf{u}_1)^T)^T$ .

For layer  $i$  ( $i > 1$ ), performing Gaussian elimination, we have

$$\mathbf{W}_i \mathbf{H}_i = (\mathbf{P}_i \mathbf{I}_{r_i}),$$

and the codeword for layer  $i$  is formed by

$$\mathbf{b}_i = (\mathbf{u}_i^T (\mathbf{P}_i \mathbf{u}_i + \mathbf{W}_i \mathbf{C}_{i-1} \mathbf{b}_{i-1})^T)^T.$$

It is clear from the encoding processing that with a nonzero  $\mathbf{C}_{i-1}$ , part of the information about layer  $i - 1$  is injected into the codeword of layer  $i$ .

## B. Decoding

Without loss of generality, assume the  $i$ th element of  $\mathbf{x}$  denoted as  $x_i$  is the signal from the  $i$ th layer, corresponding to the  $i$ th column of  $\mathbf{G}$ , denoted as  $\mathbf{g}_i$ .

Assume we are now decoding layer  $i$ . Note that decoders for layer  $i$  and  $i+1$  are both active.

### Zero-Forcing

$$z_j = \mathbf{w}_j^H \mathbf{y}, \quad j = i, i+1,$$

where the  $N_r \times 1$  unit-norm weight vector  $\mathbf{w}_j$  nulls signals from all other undecoded layers according to the zero-forcing criterion.

### Interference Cancellation

$$\tilde{z}_j = z_j - \sum_{i < j} \mathbf{w}_j^H \mathbf{g}_i \hat{x}_i, \quad j = i, i+1,$$

where  $\hat{x}_i$ 's are the reconstructed signals of decoded layers.

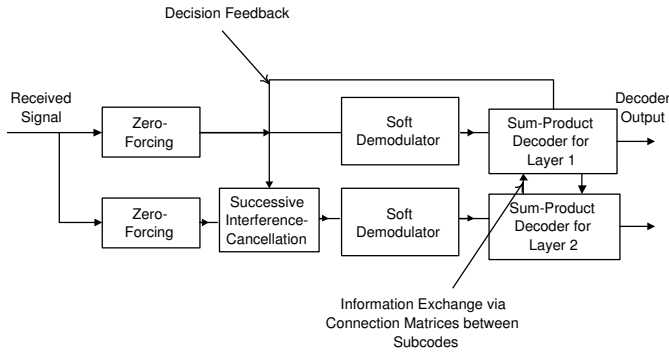

Fig. 3. Decoder for QBD-LDPC space-time codes

### LDPC Decoding (Belief Propagation)

After zero-forcing and interference cancellation, the LDPC code is decoded like a 1-dimensional code at each stage. The *log-likelihood ratio* (LLR) is defined as

$$L(a) \triangleq \ln \left( \frac{p(a=1)}{p(a=0)} \right).$$

Then the soft information from the demodulator is

$$L_{zb}(b_k) = \ln \frac{\sum_{\mathbf{b}: b_k=0} p(z|\mathbf{b}) e^{\sum_{l \in V_k} L_{bz}(b_l)}}{\sum_{\mathbf{b}: b_k=1} p(z|\mathbf{b}) e^{\sum_{l \in V_k} L_{bz}(b_l)}}, \quad j = i, i+1, \quad (1)$$

where

$$p(z|\mathbf{b}) = \frac{1}{\pi N_0} e^{-\frac{1}{N_0} |z_j - \mathbf{w}_j^H \cdot \mathbf{g}_j x_j|^2}, \quad j = i, i+1,$$

$$V_k = \{l | l \neq k \text{ and } x_l = 1\},$$

and  $\mathbf{b}$  is the bit vector mapped to signal constellation  $x_j$ .

The soft output from the demodulator is then sent to the sum-product decoder.

The message update at the variable node is

$$L_{bc}(b_k, c_l) = L_{zb}(b_k) + \sum_{\substack{c_j \in \Omega(b_k) \\ c_j \neq c_l}} L_{cb}(b_k, c_j). \quad (2)$$

and the message update at the check node is

$$L_{cb}(b_k, c_l) = L \left( \sum_{b_j \in \Omega(c_l) \setminus b_k} b_j \right), \quad (3)$$

which can be implemented efficiently by forward-backward algorithm using the property that

$$L(a+b) = \ln \frac{e^{L(a)} + e^{L(b)}}{1 + e^{L(a)+L(b)}},$$

or by the algorithm in [10]. Note that the message passing is performed between layer  $i$  and  $i+1$ , as well as within each layer.

Then the message passed to soft demodulator as a priori information is

$$L_{bz}(b_k) = \sum_{c_l \in \Omega(b_k)} L_{cb}(b_k, c_l). \quad (4)$$

The LLR for tentative decision is

$$LLR(b_k) = L_{zb}(b_k) + \sum_{c_l \in \Omega(b_k)} L_{cb}(b_k, c_l) = L_{zb}(b_k) + L_{bz}(b_k).$$

Note that one characteristic of LDPC is that the iteration can be terminated as soon as all parity checks are satisfied. In our case, we terminate the iteration when those parity checks involving only detected layers and the layer to be detected are satisfied. Take layer 1, for example. We stop the belief propagation when

$$\mathbf{H}_1 \mathbf{b}_1 = \mathbf{0},$$

is satisfied and the parity checks in

$$\mathbf{C}_1 \mathbf{b}_1 + \mathbf{H}_2 \mathbf{b}_2 = \mathbf{0},$$

are only used for exchange of information between undetected layers to improve the detection performance.

After the current layer has been successfully decoded, the LLR's of the bits in the layer is set to  $+\infty$  or  $-\infty$  depending on their values to avoid ambiguity that may cause performance loss in the detection of later layers.

## V. SIMULATION RESULTS

In this section we simulate the performance of a MIMO-OFDM system with QBD-LDPC structure. The simulated system has 2 transmit and 2 receive antennas with 64QAM modulation. IEEE 802.11 TGn channel model "F" is used. The Matlab program provided by [11] is used to generate channel parameters. The structure of a OFDM symbol conforms to the IEEE 802.11a PHY standard in the 5GHz band. 48 out of 64 subcarriers are used for data transmission in a 20MHz system bandwidth and the guard interval is  $0.8\mu\text{s}$ , resulting in a total of  $4\mu\text{s}$  symbol duration. Perfect channel estimation is assumed and the channel is assumed to be constant during each transmission. The transmission of each layer is cycled through all transmit antennas. The codeword length of each layer is 1152 bit corresponding to

4 OFDM symbols and the code rate for each layer is 1/2. Therefore, the data rate of the simulated system is 72Mbps.

The QBD-LDPC with the specified parameters is generated by the modified version of progressive edge growth construction algorithm [12].  $\mathbf{H}_1$  and  $\mathbf{H}_2$  are first generated progressively to maximize the global girth of the corresponding Tanner graph. Then the number of bits involved in each parity check equation in  $\mathbf{C}_1$  as in Figure 1 is set to 2, introducing connection between the two layers. The addition of each edge also tries to maximize the girth.

The word error rate (WER) of the proposed system is given in Figure 4. The WER of a system with independent LDPC-coded layers (V-BLAST) is provided for comparison. For a WER of 1%, the required SNR for the proposed system is 19.6dB, which is about 0.5dB better than the V-BLAST system.

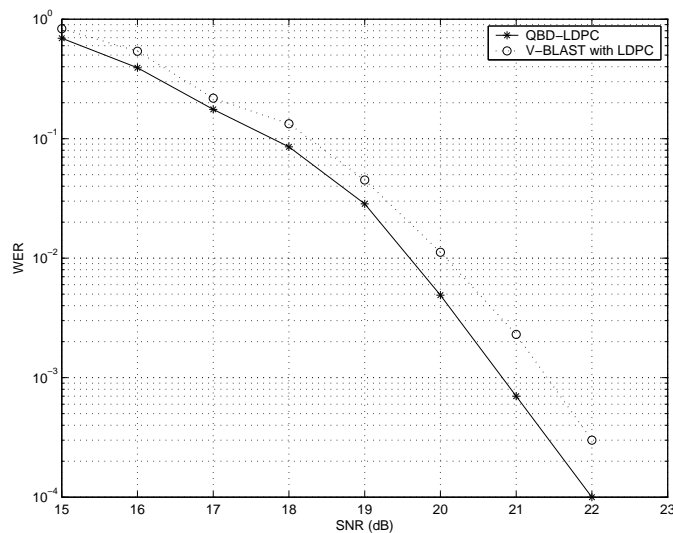

Fig. 4. WER's of layered systems

## VI. CONCLUSION

In this paper, we introduce a layered space-time coding that is characterized by the low-block triangular structure of the LDPC parity-check matrix. The layers are detected successively, each with the help of information from the next layer to enhance performance. Encoding and decoding algorithm are introduced and the simulation shows a 0.5dB improvement over the conventional LDPC-coded V-BLAST at WER=1%.

## REFERENCES

- [1] G. J. Foschini and M. J. Gans, "On the limits of wireless communications in a fading environment when using multiple antennas," *Wireless Personal Commun.*, vol. 6, pp. 315–335, Mar. 1998.
- [2] E. Telatar, "Capacity of multi-antenna gaussian channels," *European Transactions on Telecommunications*, vol. 10, pp. 585–595, Nov-Dec 1999.
- [3] R. G. Gallager, *Low-Density Parity-Check Codes*. Cambridge, MA : MIT Press, 1963.
- [4] D. J. C. MacKay, "Good error-correcting codes based on very sparse matrices," *IEEE Trans. Inform. Theory*, vol. 45, pp. 399–431, Mar. 1999.

- [5] Y. Kou, S. Lin, and M. P. C. Fossorier, "Low-density parity-check codes based on finite geometries: a rediscovery and new results," *IEEE Trans. Inform. Theory*, vol. 47, pp. 2711–2736, Nov. 2001.
- [6] P. Meshkat and H. Jafarkhani, "Space-time low-density parity-check codes," *Signals, Systems and Computers, Conference Record of the Thirty-Sixth Asilomar Conference on*, vol. 2, pp. 1117–1121, Nov. 2002.
- [7] B. Lu, X. Wang, and K. R. Narayanan, "LDPC-based space-time coded OFDM systems over correlated fading channels: performance analysis and receiver design," *IEEE Trans. Commun.*, vol. 50, pp. 74–88, Jan. 2002.
- [8] G. J. Foschini, "Layered space-time architecture for wireless communication in a fading environment when using multi-element antennas," *Bell Labs Technical Journal*, pp. 41–59, Aug. 1996.
- [9] S. Y. Chung, T. J. Richardson, and R. L. Urbanke, "Analysis of sum-product decoding of low-density parity-check codes using a Gaussian approximation," *IEEE Trans. Inform. Theory*, vol. 47, pp. 657–670, Feb. 2001.
- [10] X. Y. Hu, E. Eleftheriou, D. M. Arnold, and A. Dholakia, "Efficient implementations of the sum-product algorithm for decoding ldpc codes," *GLOBECOM 2001*, vol. 2, pp. 25–29, Nov. 2001.
- [11] L. Schumacher. WLAN MIMO channel Matlab program. [Online]. Available: [http://www.info.fundp.ac.be/~lsc/Research/IEEE\\_80211\\_HTSG\\_CMSC/distribution\\_terms.html](http://www.info.fundp.ac.be/~lsc/Research/IEEE_80211_HTSG_CMSC/distribution_terms.html)
- [12] X. Hu. Source code for progressive edge growth parity-check matrix construction. [Online]. Available: <http://www.inference.phy.cam.ac.uk/mackay/PEG-ECC.html>